

Style 22 Balustrade

Vyne Baluster combined with the Regency Rail and Plinth with Panelled Piers.

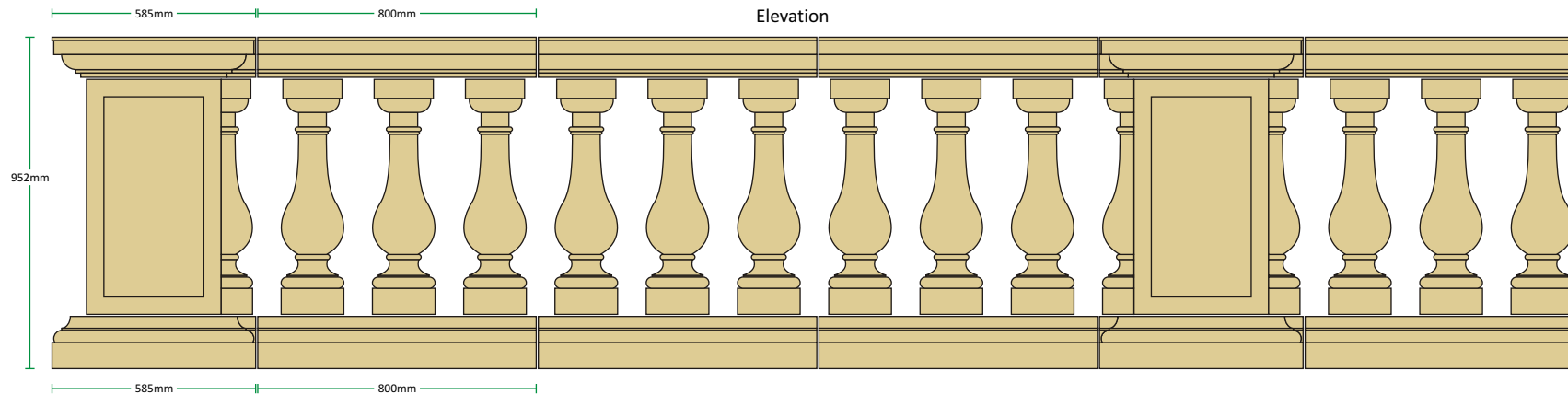

Elevation

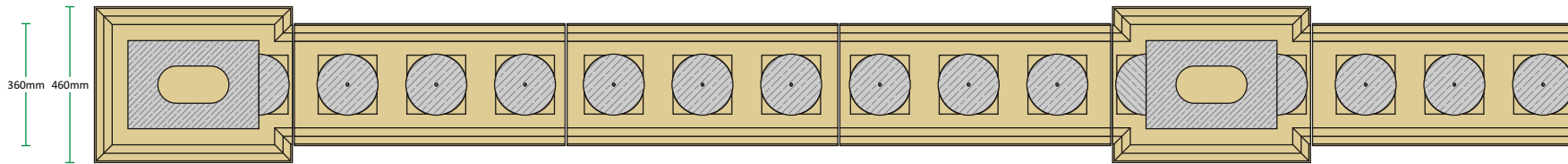

Plinth Plan

'Style 22' Balustrade		Height	Width	Length	Weight
Description	Code	(mm)	(mm)	(mm)	(Kg)
Vyne baluster	BS12A	675	180	180	29
Vyne baluster - Half	BS12AH	675	180	90	15
Vyne baluster - Sloping*	BS12B	675	180	180	29
Regency Rail	BS2C	115	352	800	54
Regency Plinth	BS2D	150	360	800	72
Regency Pier Cap - End	BS2E	115	585	460	58
Regency Pier Cap - Intermediate	BS2F	115	585	460	58
Regency Pier Cap - Corner	BS2G	115	585	585	71
Regency Pier Plinth - End	BS2H	150	585	460	76
Regency Pier Plinth - Intermediate	BS2I	150	585	460	76
Regency Pier Plinth - Corner	BS2J	150	585	585	92
Regency Pier Shaft - Panelled - 675mm	BS2L/675	675	387	280	125
Regency Pier Shaft - Panelled - Corner - 675mm	BS2LC/675	675	387	387	185

* The Sloping Vyne baluster can be made to any angle, please specify the angle required at time of ordering

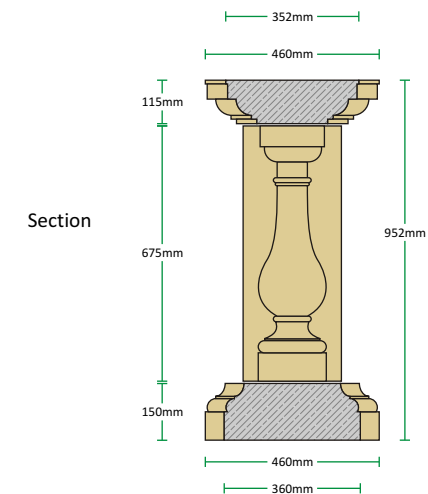

Section

All our balustrade styles feature an optional 135° Pier, please call a member of our technical team with your requirements.