

# Style 13 Balustrade

Margam Baluster combined with the Regency Rail and Plinth with Panelled Piers.

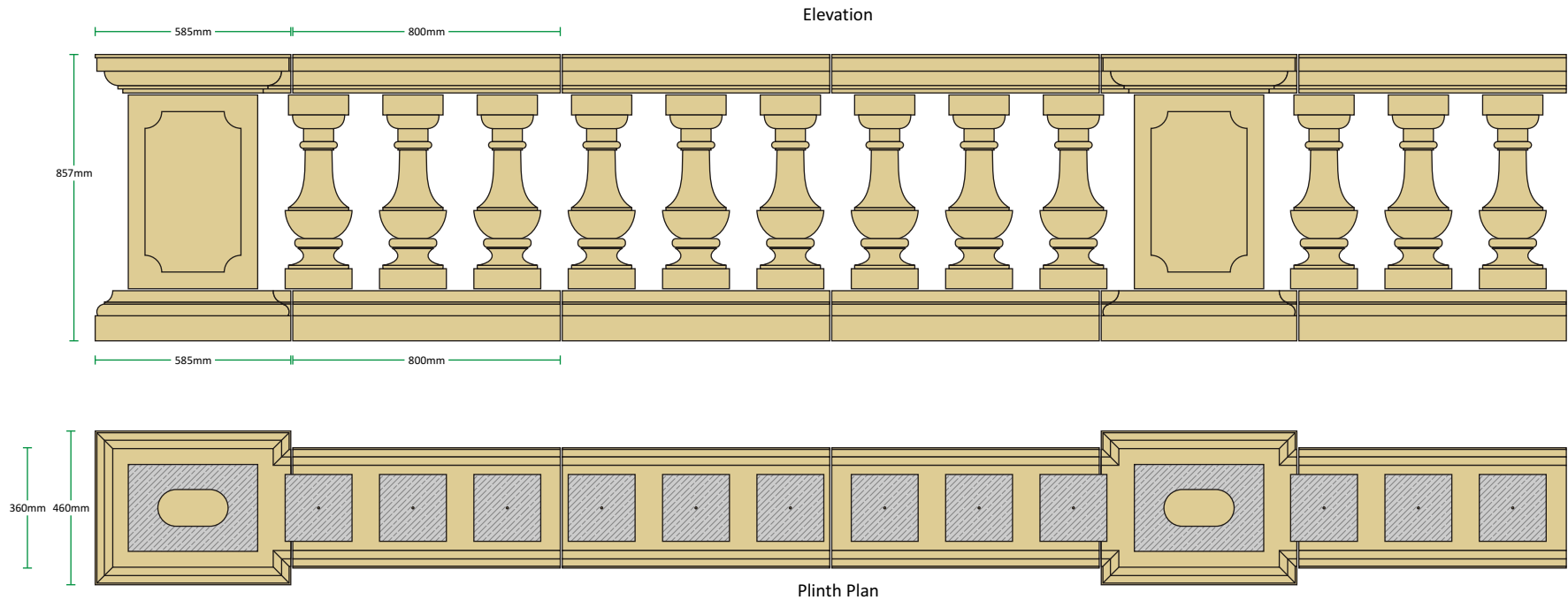

'Style 13' Balustrade		Height	Width	Length	Weight
Description	Code	(mm)	(mm)	(mm)	(Kg)
Margam baluster	BS15A	580	200	200	33
Margam baluster - Sloping*	BS15B	580	200	100	33
Regency Rail	BS2C	115	352	800	54
Regency Plinth	BS2D	150	360	800	72
Regency Pier Cap - End	BS2E	115	585	460	58
Regency Pier Cap - Intermediate	BS2F	115	585	460	58
Regency Pier Cap - Corner	BS2G	115	585	585	71
Regency Pier Plinth - End	BS2H	150	585	460	76
Regency Pier Plinth - Intermediate	BS2I	150	585	460	76
Regency Pier Plinth - Corner	BS2J	150	585	585	92
Regency Pier Shaft - Panelled	BS2L/580	580	387	260	107
Regency Pier Shaft - Panelled - Corner	BS2LC/580	580	387	387	99

\* The Sloping Margam baluster can be made to any angle, please specify the angle required at time of ordering

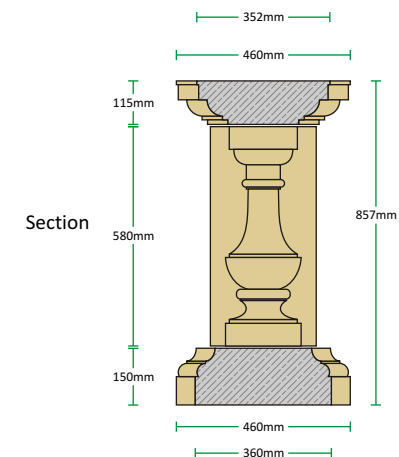

All our balustrade styles feature an optional 135° Pier, please call a member of our technical team with your requirements.